

Application of SpaceWire Technology in Hydroacoustics

Session: SpaceWire missions and applications

Authors:

Petr Eremeev

Sergey Kozyrev

Viacheslav Grishin

Research and Design Institute “SUBMICRON”

Structure of Hydroacoustic Complex

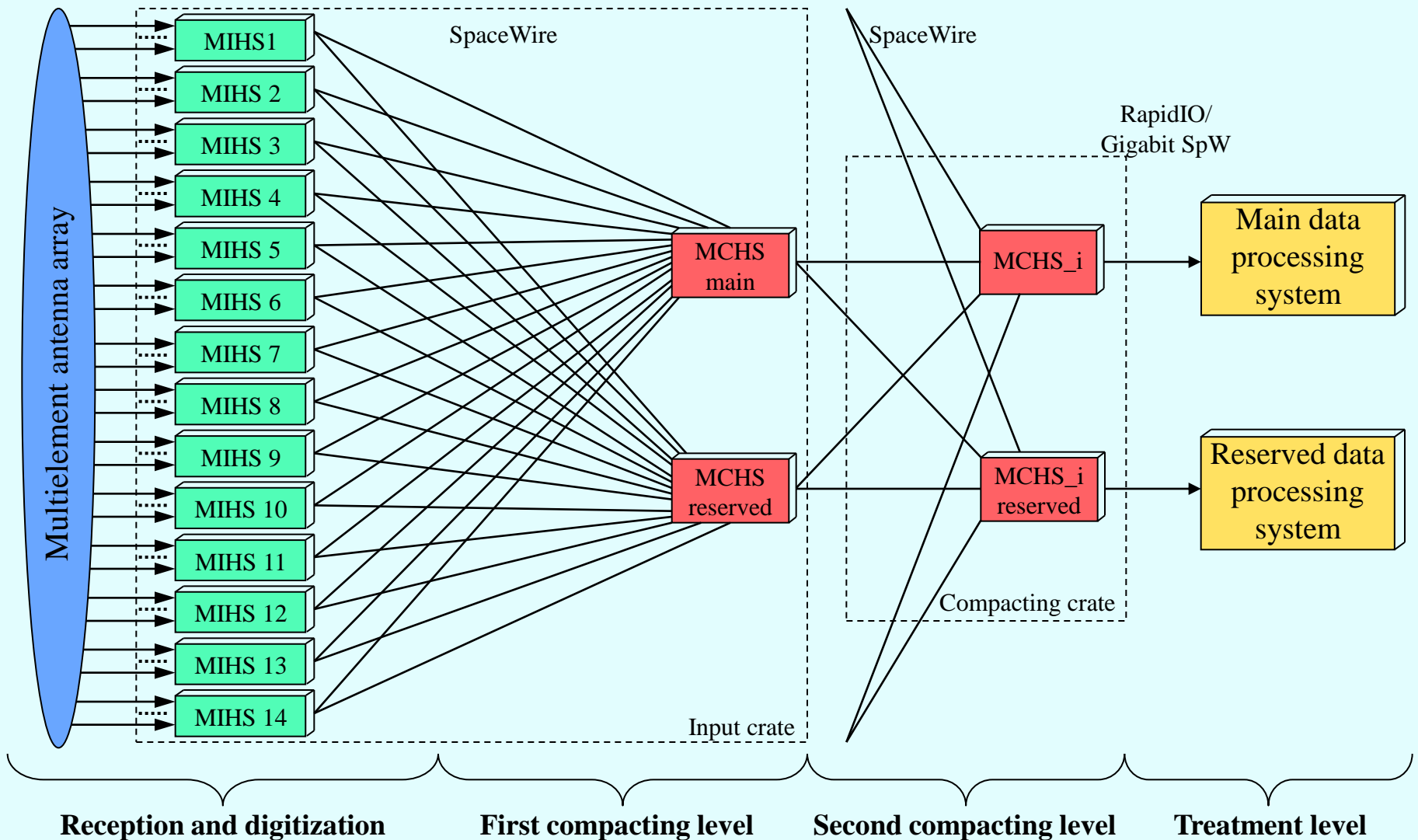

Module of Input Hydroacoustic Signals

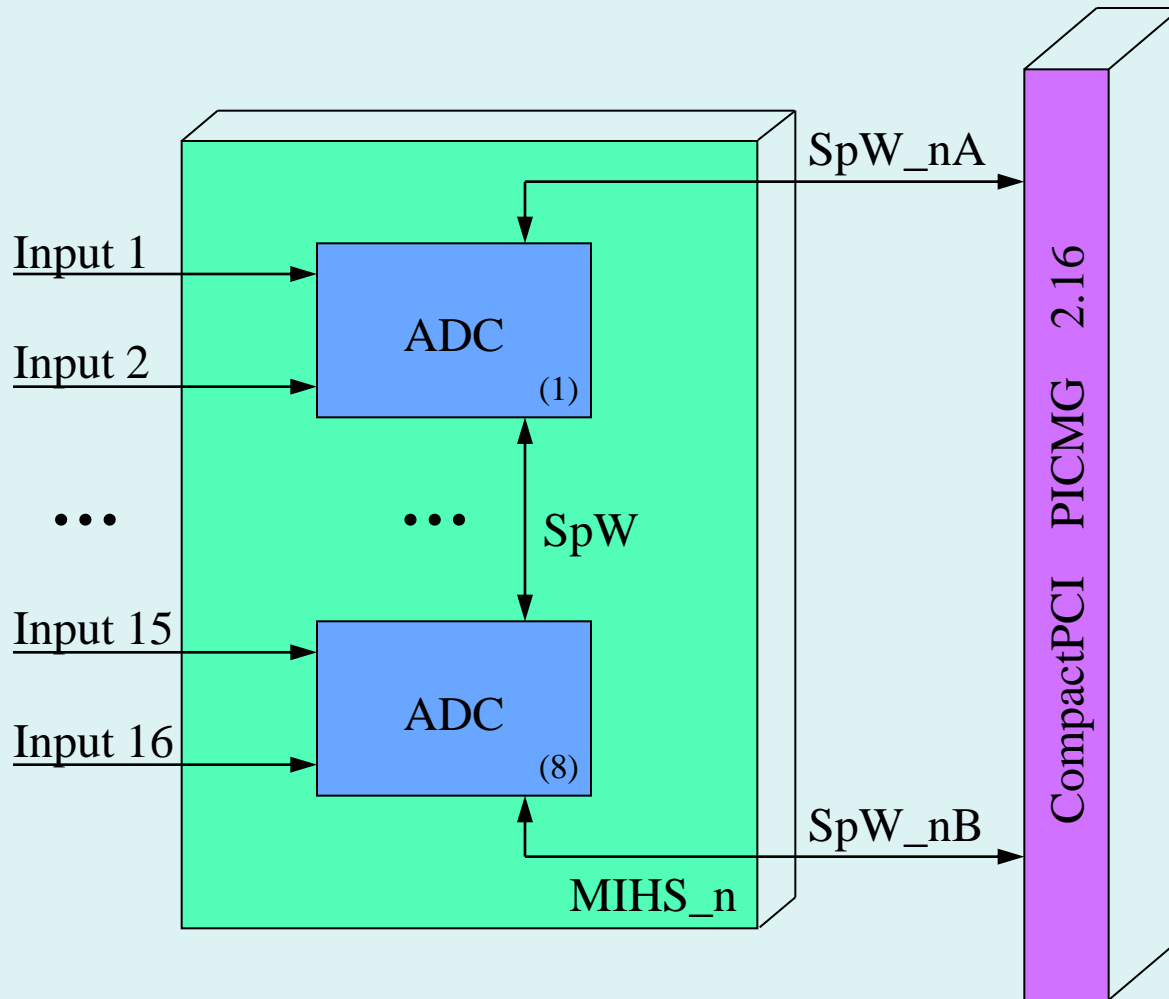

Module of Compacting Hydroacoustic Signals

